



## Main characteristics

- Strokes from 50 to 1500mm
- Sliding or floating magnetic cursor
- Direct analog output for displacement
- Standard valve or M12 connector
- Work temperature: -20...+75° C
- IP65 protection
- Power supply 24Vdc ±20%

Contactless linear position transducer with innovative GEFran ONDA magnetostrictive technology for longer lifetime. The absence of electrical contact on the cursor eliminates all wearing and guarantees almost unlimited life. The new ONDA technology solution (patented by Gefran) allows to obtain an essential modular structure with compact size for simple installation.

## TECHNICAL DATA

Model	from 50 to 1500 mm
Measurement taken	Displacement
Position read sampling time (typical)	see table
Shock test DIN IEC68T2-27	100g - 11ms - single shock
Vibrations DIN IEC68T2-6	12g / 10...2000Hz
Displacement speed	≤ 10 m/s
Max. acceleration	≤ 100 m/s <sup>2</sup> displacement
Resolution	INFINITE (only limited by the electrical noise)
Cursor (see note)	Sliding cursor Floating separate cursor
Working temperature	-20...+75° C
Storage temperature	-40...+100° C
Coefficient of temperature	≤ 0.01% f. g. ° C (min. 0,015mm/° C)
Protection	IP65

## ELECTRICAL DATA

Output signal	0, 1...10, 1V ( )	4...20mA ( )
Nominal power supply	24 Vdc ±20%	24 Vdc ±20%
Max. power ripple	1Vpp	1Vpp
Output current consumption	35mA	60mA
Output load	≥ 10K Ω	50... 500 Ω
Max. output value	12V	30mA
Alarm output value	10,5 V	21 mA
Electrical isolation	50 V	50 V
Protection against polarity inversion	Yes	Yes
Protection against overvoltage	Yes	Yes
Protection against power supply in output	Yes	Yes

## MECHANICAL DIMENSIONS

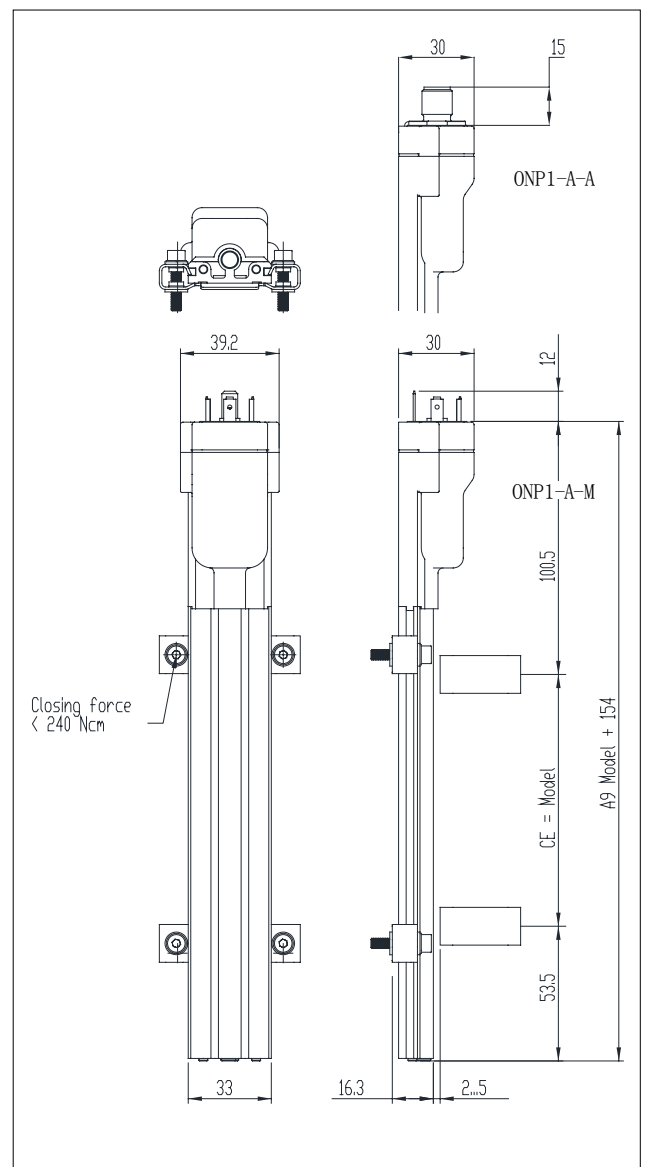

## ELECTRICAL / MECHANICAL DATA

Model		50	75	100	130	150	175	200	225	250	300	350	360	400	450	500	550	600	650	700	750	800	850	900	950	1000	1100	1200	1250	1300	1400	1500
Sampling time	ms	1										1,5					2					3										
Electrical stroke (E.S.)	mm	<b>Model</b>																														
Independent linearity		$\leq \pm 0,04\%F.S.$ (Min. $\pm 0,090$ mm)																														
Max. dimensions (A)	mm	<b>Model + 154</b>																														
Repeatability	mm	$\leq 0,01$ (typical)																														
Hysteresis	mm	$\leq 0,02$ (typical)																														

## ELECTRICAL CONNECTIONS

PIN	FUNCTION
1	Output
2	GND Output
3	n.d.
4	Power supply -
5	Power supply +

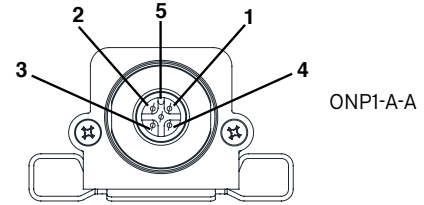

PIN	FUNCTION
1	Power supply -
2	Output
3	Power supply +
	Cable Shield (must be connected to the panel side, too)

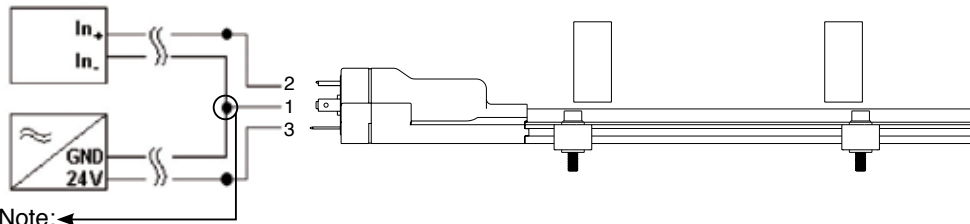
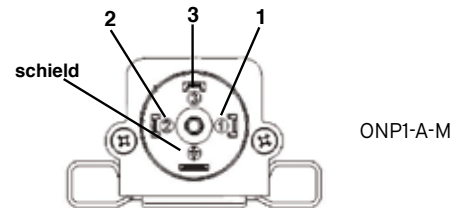

Note: Make a connection as close as possible to transducer

## ANALOG OUTPUT

The ONP1-A magnetostrictive transducers provide a direct voltage or current analogue output proportional to the magnetic cursor's position. Since the output is direct, no signal electronic processing is required if interfaced with controllers or measurement instruments.

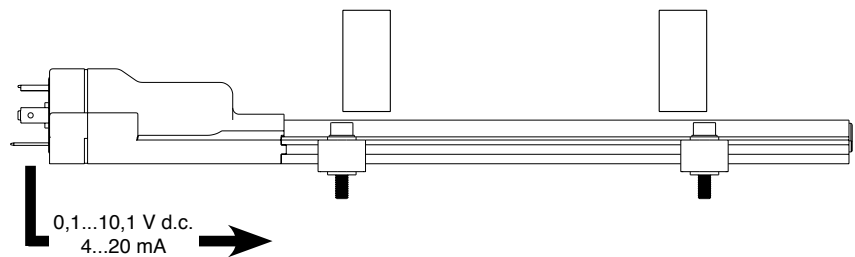

## ORDER CODE

Position transducer **O N P 1 A**

**0 0 0 0 X 0 0 0 X 0 0 X 0 X X**

Analogue output **A**

### Connector

4 pin connector output DIN 43650 ISO4400 **M**  
5 pin connector output M12 **A**

### Model

### Output

0,1...10,1 V d.c.	1 cursor only for direct output	<b>W</b>
4...20mA	1 cursor only for direct output	<b>E</b>

## CURSORS ON REQUEST

P C U R

Cursors	
Floating Cursor	034
Sliding cursor , axial joint low	135
Sliding cursor , axial joint high	136
Sliding cursor , axial joint angle	137

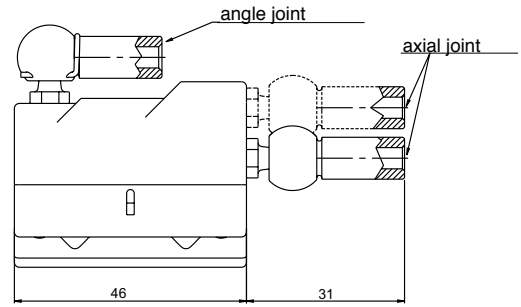

**PCUR034**

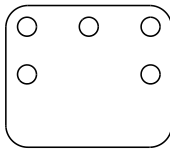

**PCUR135**

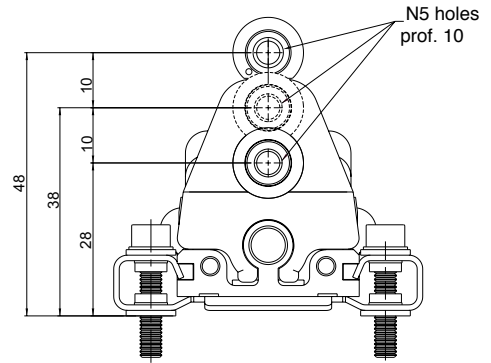
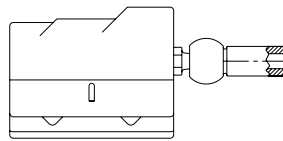

**PCUR136**

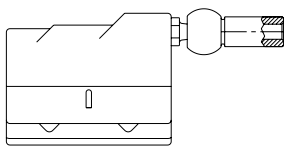

**PCUR137**

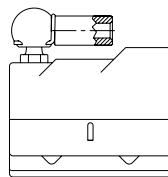

## BRACKETS ON REQUEST



P K I T

Brackets (2 brackets for every kit)	
Steel brackets, interaxis 42.5mm	590
Steel brackets, interaxis 50mm	591

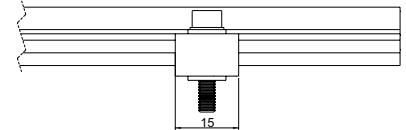
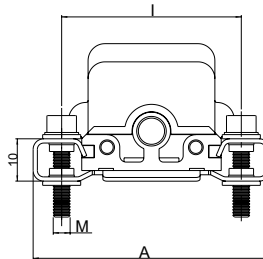

Brackets code	Interaxis (i)	Screw (V)	Dimension (A)
PKIT590	42.5	M4	56
PKIT591	50	M5	63.5

## FEMALE CONNECTORS

### ON REQUEST

4-pin 90° radial female connector DIN43650 IP65 PG9 clamp for  $\phi 6$ - $\phi 8$  mm cable

**CON006**

5-pin, axial female connector M12, IP67, clamp for  $\phi 6,5$  mm cable

**CON031**

5-pin 90° radial female connector M12, IP67 clamp for  $\phi 6$ - $\phi 8$  mm cable

**CON041**

**GEFRAN spa**

via Sebina, 74

25050 PROVAGLIO D'ISEO (BS) - ITALIA

ph. 0309888.1 - fax. 0309839063

Internet: <http://www.gefran.com>

**GEFRAN**

DTS\_ONP1-A\_08-2011\_ENG